



The

LUCKY NEEDLE

PATTERNING A SUSPENDED HEADLINER



SUSPENDED HEADLINERS, MOLDED HEADLINERS & SUN VISORS COURSE EBOOK

All content belongs to The Lucky Needle and may not be re-used
or resold in any way without consent of The Lucky Needle.



PATTERNING A SUSPENDED HEADLINER FROM SCRATCH

Welcome to the Suspended Headliners, Molded Headliners & Sun Visors Course! You will notice that patterning a suspended headliner from scratch is not covered in the course videos. Read more to learn why and see how you can make your own suspended headliner pattern!



“Hey Everyone! I get asked all the time why I did not include patterning a suspended headliner from scratch in the Suspended Headliners, Molded Headliners & Sun Visors Course. I personally feel there are better options available than taking all the time and money to pattern a headliner from scratch, hopefully as you read on, you’ll see why. If you do decide making a pattern from scratch is still the best option for you, don’t worry I will explain this option as well!”

PATTERNING A SUSPENDED HEADLINER FROM SCRATCH

Patterning a suspended headliner from scratch is a very time-consuming and sometimes expensive process. These days, you can buy a ready-made headliner for basically any car and they are actually pretty inexpensive. On the jobs that require a custom color to match to the rest of the interior, you can still purchase an inexpensive ready-made headliner, cut it apart, and use this for your pattern. We feel the time you save by patterning your headliner this way, far outweighs the cost of the new headliner. Plus, now you have that pattern forever and can reuse it next time!

One of the only scenarios where this technique does not work, is on a car that has had the roof chopped or modified in some way. However, even in this circumstance, it’s very unlikely that someone will go through all the effort to modify their car that much, and then afterwards want to install a suspended headliner. Those projects almost always have one-piece solid headliners custom made.

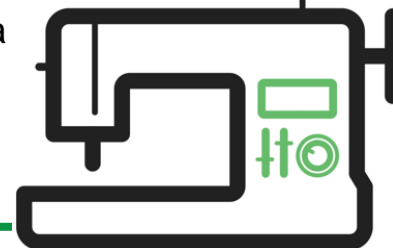



PATTERNING A SUSPENDED HEADLINER FROM SCRATCH

If you decide that using a ready-made headliner as a pattern is not right for you, you can pattern a suspended headliner from scratch. There are two options that will work well for this.

OPTION ONE

Some cars that have a relatively flat roof. This means you can measure the roof for your headliner, without needing to pattern it.

- Measure the distance between each bow and cut out the strips matching those measurements.
- Sew on the listing for the bows to slide in to and install it.

If you are using a stretchy material like vinyl you will want to sew it up a little tighter to account for the stretch.

MEASURE THIS DISTANCE

SEW ON LISTING FOR BOWS

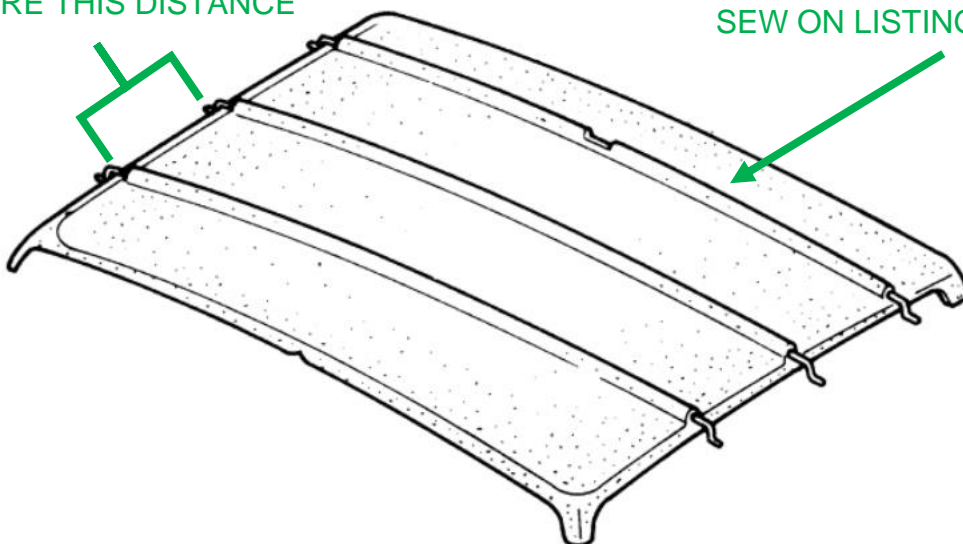



OPTION TWO

On many cars the roof is not flat at all and you will need to create your own pattern to make your headliner, if you decide that is the right route for you.

- To make a pattern, start by positioning the bows in the car where they should sit once the headliner is installed. We have seen people do this using tape or string to secure the bows held in the right position. We have also seen people glue a layer of Dacron on to the roof for insulation. Often that Dacron will be enough pressure on the bows to hold them in place.
- Once the bows are in place, draw alignment marks on the bows to reference when sewing.
- Then cover the bows in a layer of [Basting Tape](#).
- Next, use either some clear plastic sheeting or thin gauge clear vinyl to cover the bows, sticking your clear material to the basting tape on the bows. The clear plastic or vinyl should be laid flat with no wrinkles.
- Next, transfer your seam and alignment marks from the bows to the clear vinyl. Also make sure to number the pattern, to ensure that you sew each piece in the right order.
- Once you have drawn your seam and alignment marks, cut out your clear material and to create your pattern.
- Repeat this process for each section of the headliner until you have a pattern for the entire headliner.
- This process is very similar to patterning a Bimini top on a boat just upside down. You may find this video useful:
 - [How to Make a 4 Bow Bimini Top](#)